

RAY OPTICS

1. RECTILINEAR PROPAGATION OF LIGHT

It is a well established fact that light is a wave. Although, a light wave spreads as it moves away from its source, we can approximate its path as a straight line. Under this approximation, we show light as a ray and the study of light as a ray is called ray optics or geometrical optics.

1.1 Ray

The straight line path along which light travels in a homogeneous medium is called a ray.

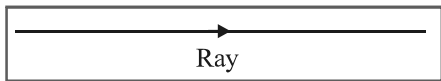

2. REFLECTION OF LIGHT

The phenomenon in which a light ray is sent back into the same medium from which it is coming, on interaction with a boundary, is called reflection. The boundary can be a rigid surface or just an interface between two media.

2.1 Law of Reflection

We have few angles to define before considering law of reflection

- (i) **Angle of incidence :** The angle which the incident ray makes with normal at the point of incidence.
- (ii) **Angle of reflection :** The angle which the reflected ray makes with normal at the point of incidence.

A reflected ray lies in the plane of incidence and has an angle of reflection equal to the angle of incidence. $\angle i = \angle r$.

2.2 Deviation

When a ray of light suffers reflection, its path is changed. The angle between its direction after reflection and the direction before reflection is called the deviation.

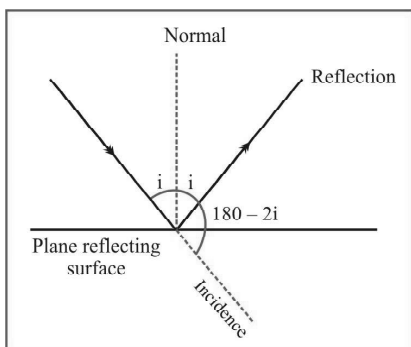

As shown in the figure, the angle between reflected ray and incident ray is $180 - 2i$ where i is the angle of incidence. Maximum deviation is 180° , when angle of incident i is zero.

2.3 Law of Reflection in Vector Form

Say unit vector along incident ray = \hat{u} .

Unit vector along normal = \hat{n}

Unit vector along reflected ray = \hat{r}

Then $\hat{r} = \hat{u} - 2(\hat{u} \cdot \hat{n}) \hat{n}$

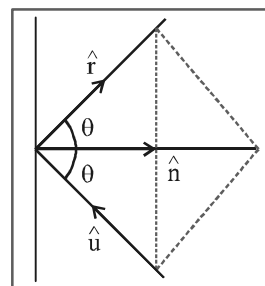

Laws of reflection remain the same whether the reflected surface is plane or curved.

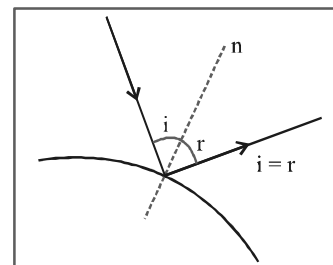

2.4 Reflection by a plane surface

Suppose a reflecting surface is rotated by an angle θ (say anticlockwise), keeping the incident ray fixed then the reflect ray rotates by 2θ along the same sense, i.e., anticlockwise.

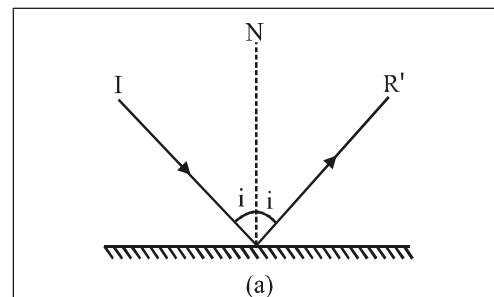

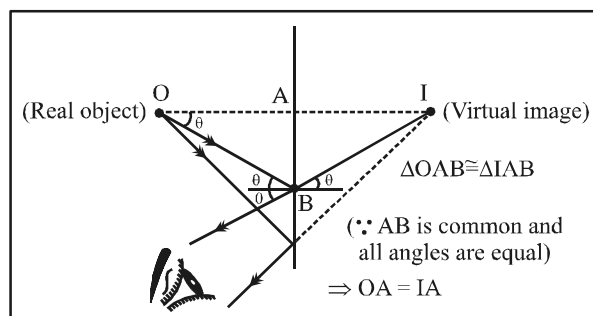
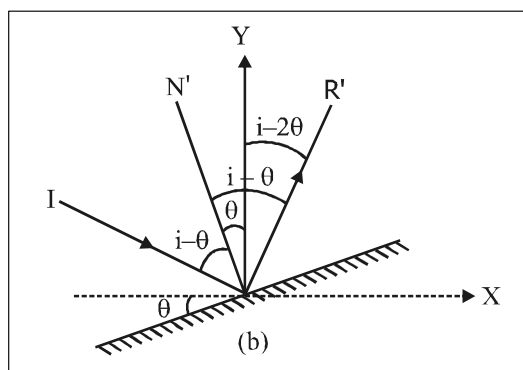

Magnification of a plane mirror is unity.

The image is formed behind the mirror. It is erect. Virtual and laterally inverted.

Image formation by two inclined mirrors, inclined at angle $= \theta \in [0, 180^\circ]$

The object and all its images will always lie on a circle, having center at the point of intersection of the two inclined mirrors, in a two dimensional view.

2.5 Reflection from plane mirror

When an object is placed in front of a plane mirror, its image can be seen behind the mirror. The distance of the object from the mirror is equal to the distance of the image from the mirror.

$(360^\circ/\theta)$		Number of Distinct images formed				Constraint or necessary condition						
Even Integer		$(360^\circ/\theta) - 1$				Object may be anywhere between the two mirrors						
θ	180°	90°	60°	45°	36°	30°	22.5°	20°	18°	15°	12°	
Images	1	3	5	7	9	11	15	17	19	23	29	

$(360^\circ/\theta)$		Number of Distinct images formed				Constraint or necessary condition						
Odd Integer		$(360^\circ/\theta)$ $(360^\circ/\theta) - 1$				A – Object NOT on the angle bisector of mirrors B – Object ON the angle bisector of mirrors						
θ		120°	72°	40°	24°			120°	72°	40°	24°	
Images	A	3	5	9	15		B	2	4	8	14	

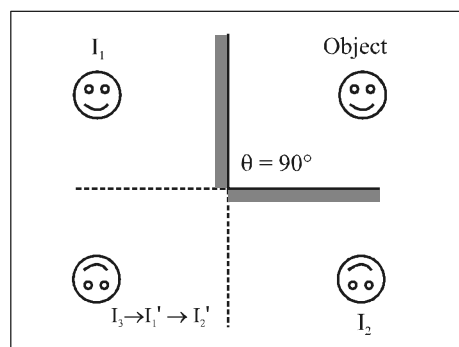

3. OTHER IMPORTANT INFORMATIONS

- (i) When the object moves with speed u towards (or away) from the plane mirror then image also moves toward (or away) with speed u . But relative speed of image w.r.t. object is $2u$.
- (ii) When mirror moves towards the stationary object with speed u , the image will move with speed $2u$.

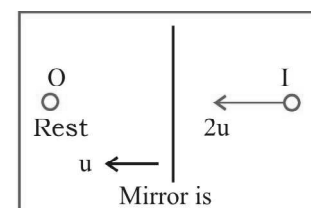
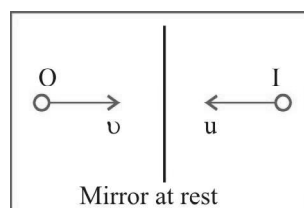

4. SPHERICAL MIRRORS

A spherical mirror is a part of sphere. If one of the surfaces is silvered, the other surface acts as the reflecting surface. When convex face is silvered, and the reflecting surface is concave, the mirror is called a concave mirror. When its concave face is silvered and convex face is the reflecting face, the mirror is called a convex mirror.

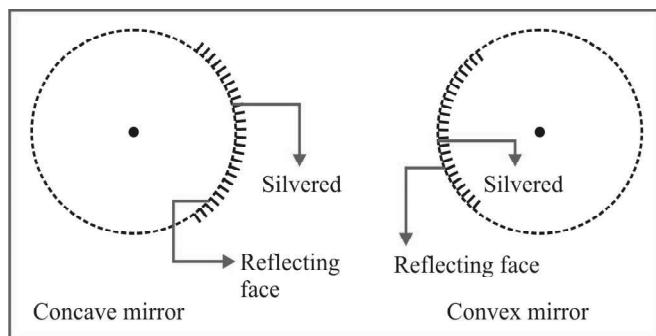

Before the discussion of reflection by curved mirrors, you shall carefully comprehend the meaning of following terms

- (i) Centre of curvature : Centre of curvature is the centre of sphere of which, the mirror is a part.
- (ii) Radius of curvature : Radius of curvature is the radius of sphere of which, the mirror is a part.
- (iii) Pole of mirror : Pole is the geometric centre of the mirror.
- (iv) Principal axis : Principal axis is the line passing through the pole and centre of curvature.
- (v) Normal : Any line joining the mirror to its centre of curvature is a normal.

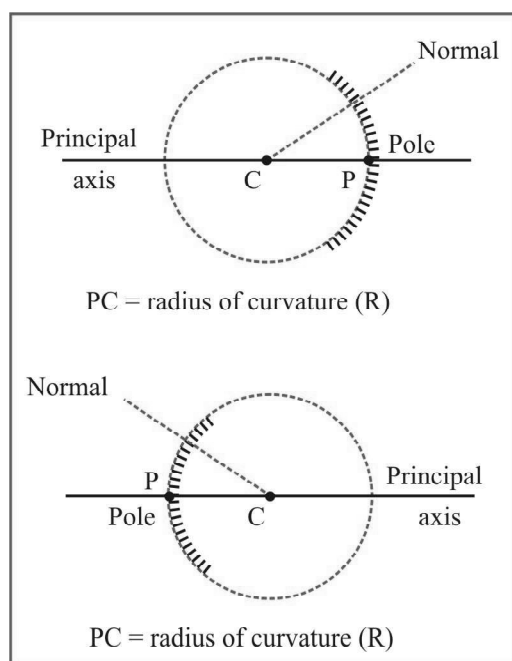

Paraxial rays : Rays which are close to principal axis and make small angles with it, i.e., they are nearly parallel to the axis, are called paraxial rays. Our treatment of spherical mirrors will be restricted to such rays which means we shall consider only mirrors of small aperture. In diagrams, however, they will be made larger for clarity.

Images formed by spherical mirrors

Let us consider various cases depending on the nature of the object and the image

(i) Real object and real image

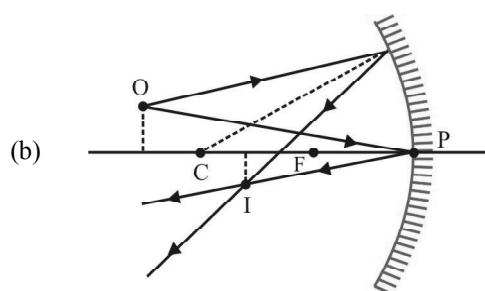
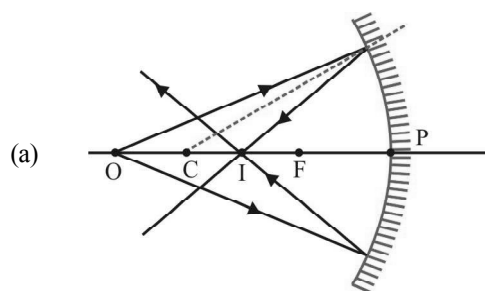

(ii) Real object and virtual image

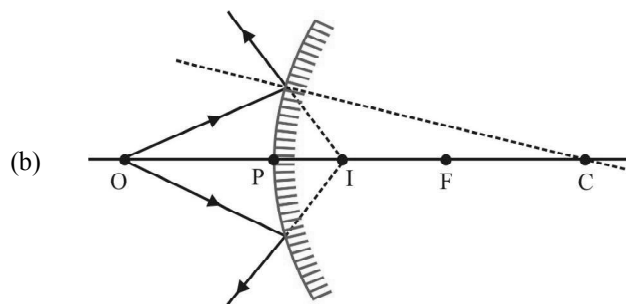
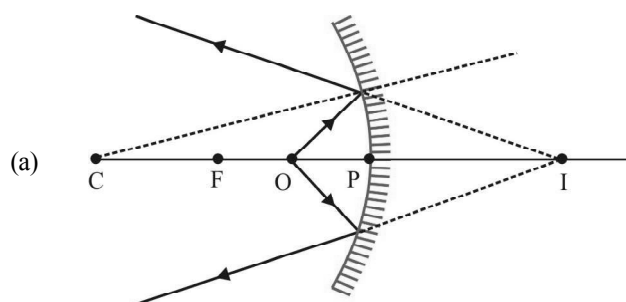

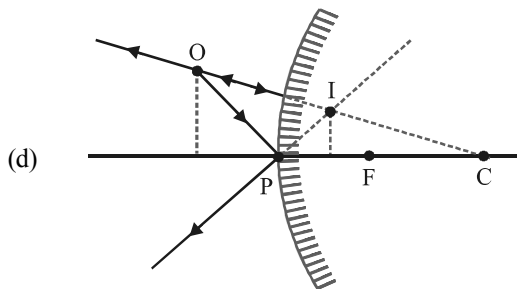
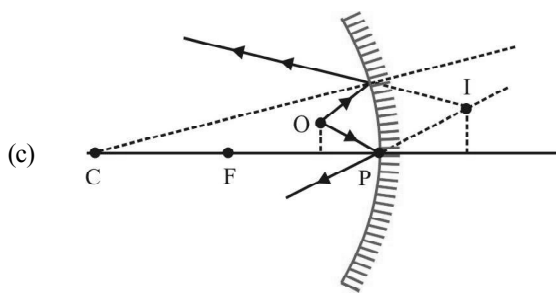

(iii) **Virtual object and real image**

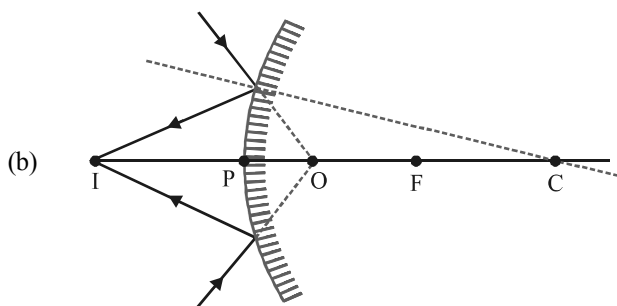
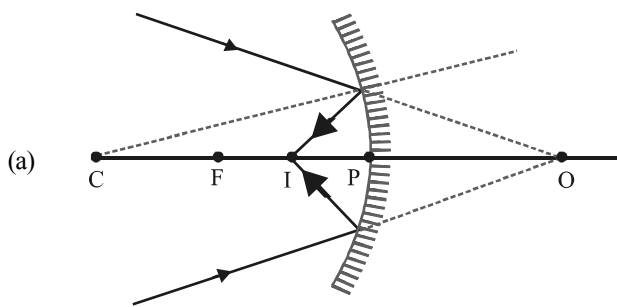

(iv) **Virtual object and virtual image**

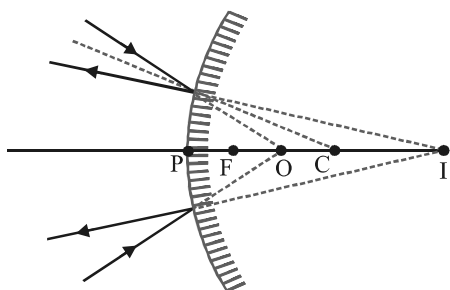

Ray diagrams

We shall consider the small objects and mirrors of small aperture so that all rays are paraxial. To construct the image of a point

object two of the following four rays are drawn passing through the object. To construct the image of an extended object the image of two end points is only drawn. The image of a point object lying on principles axis is formed on the principal axis itself. The four rays are as under :

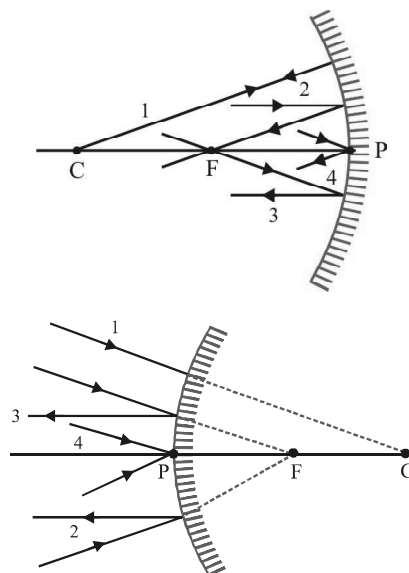

Ray 1 : A ray through the centre of curvature which strikes the mirror normally and is reflected back along the same path.

Ray 2 : A ray parallel to principal axis after reflection either actually passes through the principal focus F or appears to diverge from it.

Ray 3 : A ray passing through the principal focus F or a ray which appears to converge at F is reflected parallel to the principal axis.

Ray 4 : A ray striking at pole P is reflected symmetrically back in the opposite side.

4.1 Sign conventions

- (i) All distances are measured from the pole.
- (ii) Distances measured in the direction of incident rays are taken as positive while in the direction opposite of incident rays are taken negative.
- (iii) Distances above the principle axis are taken positive and below the principle axis are taken negative.

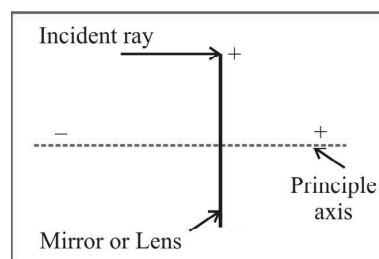

Note.. Same sign convention are also valid for lenses.

RAY OPTICS

Position, size and nature of image formed by the spherical mirror

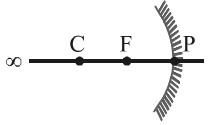
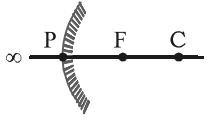
Mirror	Location of the object	Location of the image	Magnification, Size of the image	Nature		
				Real virtual	Erect inverted	
(a) Concave	At infinity i.e. $u = \infty$	At focus i.e. $v = f$	$m \ll 1$, diminished	Real	inverted	
	Away from centre of curvature ($u > 2f$)	Between f and $2f$ i.e. $f < v < 2f$	$m < 1$, diminished	Real	inverted	
		At centre of curvature $u = 2f$	At centre of curvature i.e. $v = 2f$	$m = 1$, same size as that of the object	Real	inverted
	Between centre of curvature and focus : $F < u < 2f$	Away from the centre of curvature $v > 2f$	$m > 1$, magnified	Real	inverted	
	At focus i.e. $u = f$	At infinity i.e. $v = \infty$	$m = \infty$, magnified	Real	inverted	
(b) Convex	Between pole and focus $u < f$	$v > u$	$m > 1$ magnified	Virtual	erect	
	At infinity i.e. $u = \infty$	At focus i.e., $v = f$	$m < 1$, diminished	Virtual	erect	
		Anywhere between infinity and pole	Between pole and focus	$m < 1$, diminished	Virtual	erect

Use following sign while solving the problem

	Concave mirror		Convex mirror
	Real image ($u \geq f$)	Virtual image ($u < f$)	
Distance of object	$u \rightarrow -$	$u \rightarrow -$	$u \rightarrow -$
Distance of image	$v \rightarrow -$	$v \rightarrow +$	$v \rightarrow +$
Focal length	$f \rightarrow -$	$f \rightarrow -$	$f \rightarrow +$
Height of object	$O \rightarrow +$	$O \rightarrow +$	$O \rightarrow +$
Height of image	$I \rightarrow -$	$I \rightarrow +$	$I \rightarrow +$
Radius of curvature	$R \rightarrow -$	$R \rightarrow -$	$R \rightarrow +$
Magnification	$m \rightarrow -$	$m \rightarrow +$	$m \rightarrow +$

4.2 Relation between f and R

In figure, P is pole, C is centre of curvature and F is principal focus of a concave mirror of small aperture. Let a ray of light AB be incident on the mirror in a direction parallel to the principal axis of the mirror. It gets reflected along BF. Join CB. It is normal to the mirror at B.

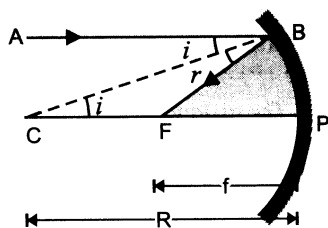

- ∴ $\angle ABC = i$, angle of incidence
- $\angle CBF = r$, angle of reflection
- Now $\angle BCF = \angle ABC = i$ (alternate angles)
- In $\triangle CBF$, as $i = r$ (law of reflection)
- ∴ $CF = FB$
- But $FB = FP$ (\because aperture is small)
- ∴ $CF = FP$

i.e., F is the centre of PC

∴ $PF = \frac{1}{2} PC$, Using sign conventions,

$PF = -f$ and $PC = -R$.

Therefore, $-f = -R/2$ or $f = R/2$

i.e., focal length of a concave mirror is equal to half the radius of curvature of the mirror.

4.3 Deriving the Mirror Formula

Mirror formula can be derived for any of the cases of image formation shown before. When we derive a formula, we keep in mind the sign conventions and substitute each value with sign. This makes a formula suitable to be applied in any case. Here, we shall derive the formula for two cases.

Real object and real image (concave mirror)

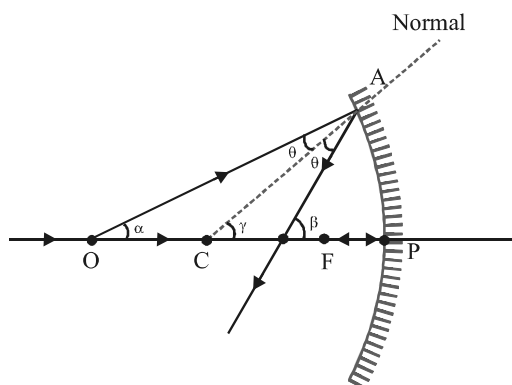

$PO = -u$ (distance of object)
 $PC = -R$ (radius of curvature)
 $PI = -v$ (distance of image)

In $\triangle OAC$, $\gamma = \alpha + \theta$... (i)
 In $\triangle OAI$, $\beta = \alpha + 2\theta$... (ii)

From (i) and (ii)
 $2(\gamma - \alpha) = \beta - \alpha$
 $\Rightarrow \beta + \alpha = 2\gamma$

$\beta = \frac{AP}{PI}$, $\alpha = \frac{AP}{PO}$, $\gamma = \frac{AP}{PC}$

$\frac{AP}{PI} + \frac{AP}{PO} = \frac{2AP}{PC}$

$\frac{1}{-v} + \frac{1}{-u} = \frac{2}{-R} \Rightarrow \frac{1}{v} + \frac{1}{u} = \frac{1}{f}$

Real object and virtual image (convex mirror)

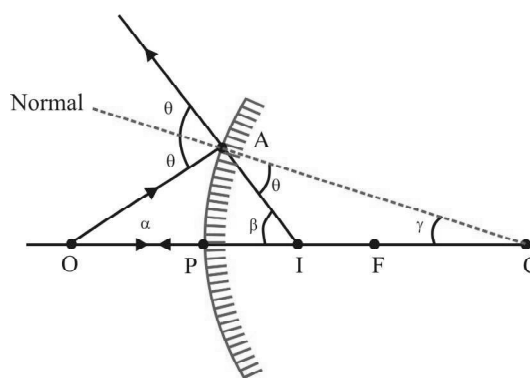

$PO = -u$ (distance of object)
 $PI = +v$ (distance of image)
 $PC = +R$ (radius of curvature)

In $\triangle OAC$, $\theta = \alpha + \gamma$... (i)
 In $\triangle OAI$, $2\theta = \alpha + \beta$... (ii)

From (i) and (ii)
 $2(\alpha + \gamma) = \alpha + \beta$
 $\Rightarrow \beta - \alpha = 2\gamma$

$\beta = \frac{AP}{PI}$, $\alpha = \frac{AP}{PO}$, $\gamma = \frac{AP}{PC}$

$\frac{AP}{PI} - \frac{AP}{PO} = \frac{2AP}{PC}$

$\frac{1}{v} - \frac{1}{-u} = \frac{2}{R} \Rightarrow \frac{1}{v} + \frac{1}{u} = \frac{1}{f}$

RAY OPTICS

While deriving the above result, if we do not use sign convention, results obtained will be different for different cases.

4.4 Magnification

The linear magnification produced by a mirror is defined as

$$\frac{\text{height of image}}{\text{height of object}}$$

$$m = \frac{I}{O} = \frac{-BB'}{AA'}$$

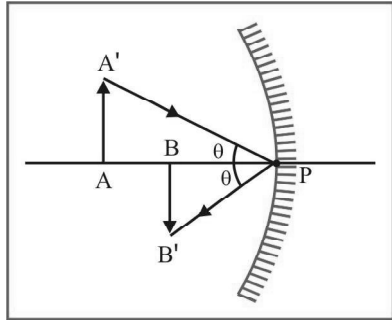

$$PB = -v \text{ (distance of image)}$$

$$PA = -u \text{ (distance of object)}$$

$$\text{Now, } \Delta A'AP \sim \Delta B'BP \Rightarrow \frac{B'B}{A'A} = \frac{BP}{AP}$$

$$\Rightarrow m = \frac{-PB}{PA} = \frac{-(-v)}{(-u)} = \frac{-v}{u}$$

Note...

$$\text{By mirror formula, } \frac{1}{v} + \frac{1}{u} = \frac{1}{f}$$

$$\Rightarrow -1 - \frac{v}{u} = \frac{-v}{f} \Rightarrow m = 1 - \frac{v}{f} = \frac{f-v}{f}$$

$$\text{Also, } \frac{1}{v} + \frac{1}{u} = \frac{1}{f} \Rightarrow \frac{-u}{v} - 1 = \frac{-u}{f} \Rightarrow m = \frac{f}{f-u}$$

$$\therefore m = \frac{-v}{u} = \frac{f-v}{f} = \frac{f}{f-u}$$

The magnification is negative when image is inverted and positive when image is erect.

If an object is placed with its length along the principal axis, then so called longitudinal magnification becomes,

$$m_L = \frac{I}{O} = -\left(\frac{v_2 - v_1}{u_2 - u_1}\right) = -\frac{dv}{du} \text{ (for small objects)}$$

$$\text{From, } \frac{1}{v} + \frac{1}{u} = \frac{1}{f} \text{ we have } -v^{-2}dv - u^{-2}du = 0$$

$$\text{or } \frac{dv}{du} = -\left(\frac{v}{u}\right)^2$$

$$\text{or } m_L = -\frac{dv}{du} = \left(\frac{v}{u}\right)^2 = m^2$$

If we differentiate the mirror formula

$$\frac{1}{v} + \frac{1}{u} = \frac{1}{f}$$

with respect to time, we get

$$-v^{-2} \cdot \frac{dv}{dt} - u^{-2} \frac{du}{dt} = 0 \quad (\text{as } f = \text{constant})$$

$$\text{or } \frac{dv}{dt} = -\left(\frac{v^2}{u^2}\right) \frac{du}{dt} \quad \dots(\text{iii})$$

As every part of mirror forms a complete image, if a part of the mirror is obstructed, full image will be formed but intensity will be reduced.

5. REFRACTION OF LIGHT

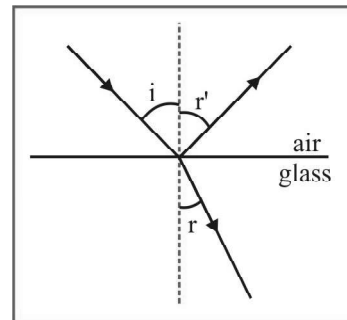

When a ray of light is incident on the boundary between two transparent media, a part of it passes into the second medium with a change in direction.

This phenomenon is called refraction.

5.1 Refractive Index

Absolute refractive index of a medium is defined by the ratio of speed of light in vacuum to speed of light in the medium $\mu = \frac{c}{v}$,

where c is speed of light in vacuum and v is the speed of light in the medium.

5.2 Law of Refraction (Snell's Law)

A refracted ray lies in the plane of incidence and has an angle of refraction related to angle of incidence by $\mu_1 \sin i = \mu_2 \sin r$. Where,

- (i) i = angle of incidence in medium 1
- (ii) μ_1 = refractive index of medium 1 (it is a dimensionless constant)
- (iii) r = angle of refraction in medium 2
- (iv) μ_2 = refractive index of medium 2
- (v) If $\mu_1 = \mu_2$, then $r = i$. The light beam does not bend
- (vi) If $\mu_1 > \mu_2$, then $r > i$. Refraction bends the light away from normal
- (vii) If $\mu_1 < \mu_2$, then $r < i$. Refraction bends the light towards the normal

A medium having greater refractive index is called denser medium while the other medium is called rarer medium.

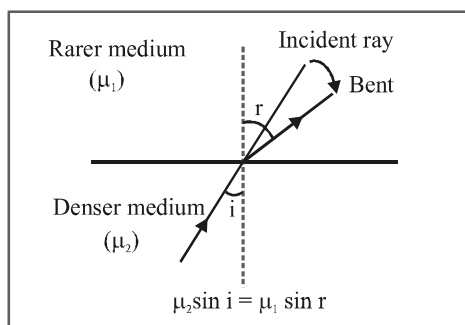
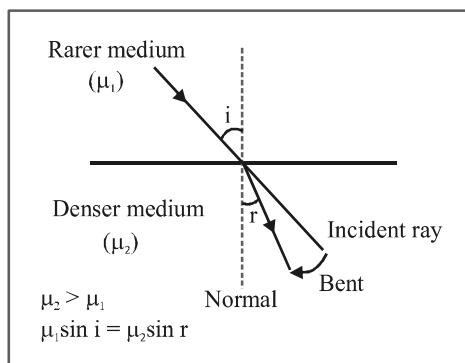

The three conditions required to find the unit vector along the refracted ray = r (provided we are given the unit vector along the incident ray = u , and the normal unit vector shown in the figure, from medium-1 towards medium-2) are

1. $|r| = 1$
2. Snell's law
3. u, n and r are coplanar \Rightarrow $STP = 0 = r \cdot (u \times n)$

Note...

$$\cos i = (u \cdot n) ; \cos r = (r \cdot n)$$

5.3 Single Refraction from a Plane Surface

Real and Apparent Depth

When an object placed in a medium is seen from another medium, its apparent position is different from the actual position. Consider the following figure.

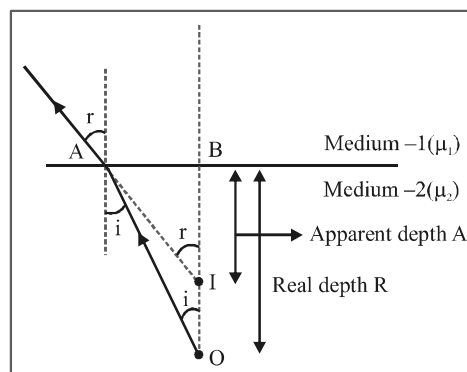

We shall derive the expression for small angles (or you can say that the object is being seen from top). By Snell's law,

$$\mu_2 \times \sin i = \mu_1 \times \sin r \text{ or, } \mu_2 \times i = \mu_1 \times r$$

$$i = \frac{AB}{R}, r = \frac{AB}{A} \Rightarrow \mu_2 \times \frac{AB}{R} = \mu_1 \times \frac{AB}{A} \Rightarrow \frac{\mu_2}{R} = \frac{\mu_1}{A}$$

The following possibilities may arise.

- (i) When observer is in air and the object is in a medium of refractive index μ ,

$$\text{You have, } \frac{\mu}{R} = \frac{1}{A} \Rightarrow A = \frac{R}{\mu}$$

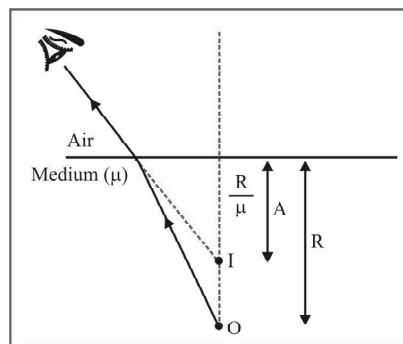

- (ii) When observer is in a medium of refractive index μ and the object is in air, you have

$$\frac{1}{R} = \frac{\mu}{A} \Rightarrow A = \mu R$$

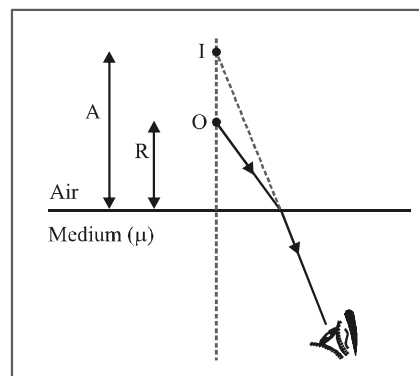

5.4 Shift due to a Glass Slab (Double Refraction from Plane Surfaces)

(i) **Normal Shift** : Here, again two cases are possible.

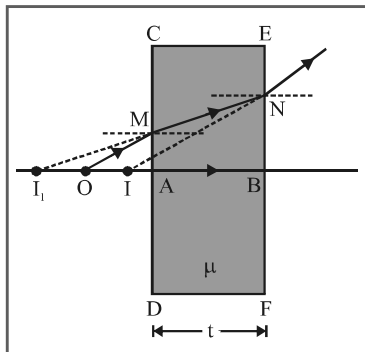

An object is placed at O. Plane surface CD forms its image (virtual) at I_1 . This image acts as object for EF which finally forms the image (virtual) at I. Distance OI is called the normal shift and its value is,

$$OI = \left(1 - \frac{1}{\mu}\right) t$$

This can be proved as under :

Let $OA = x$ then $AI_1 = \mu x$ (Refraction from CD)

$BI_1 = \mu x + t$

$BI = \frac{BI_1}{\mu} = x + \frac{t}{\mu}$ (Refraction from EF)

$\therefore OI = (AB + OA) - BI = (t + x) - \left(x + \frac{t}{\mu}\right)$

$= \left(1 - \frac{1}{\mu}\right) t$ Hence Proved.

(ii) **Lateral Shift** : We have already discussed that ray MA is parallel to ray BN. But the emergent ray is displaced laterally by a distance d, which depends on μ , t and i and its value is given by the relation,

$$d = t \left(1 - \frac{\cos i}{\sqrt{\mu^2 - \sin^2 i}}\right) \sin i$$

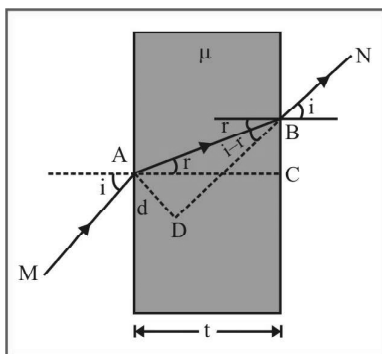

Proof: $AB = \frac{AC}{\cos r} = \frac{t}{\cos r}$
(as $AC = t$)

Now, $d = AB \sin(i - r) = \frac{t}{\cos r} [\sin i \cos r - \cos i \sin r]$

or $d = t [\sin i - \cos i \tan r]$... (i)

Further $\mu = \frac{\sin i}{\sin r}$ or $\sin r = \frac{\sin i}{\mu}$

$\therefore \tan r = \frac{\sin i}{\sqrt{\mu^2 - \sin^2 i}}$

Substituting in eq. (i), we get,

$$d = \left[1 - \frac{\cos i}{\sqrt{\mu^2 - \sin^2 i}}\right] t \sin i$$

Hence Proved.

Exercise : Show that for small angles of incidence,

$$d = ti \left(\frac{\mu - 1}{\mu}\right)$$

Apparent distance from observer

$$= \mu_{\text{observer}} \left(\frac{h_1}{\mu_1} + \frac{h_2}{\mu_2} + \dots + \frac{h_n}{\mu_n}\right)$$

5.5 Total Internal Reflection

Consider an object placed in a denser medium 2 (having refractive index μ_2) being seen from a rarer medium 1 (having refractive index μ_1)

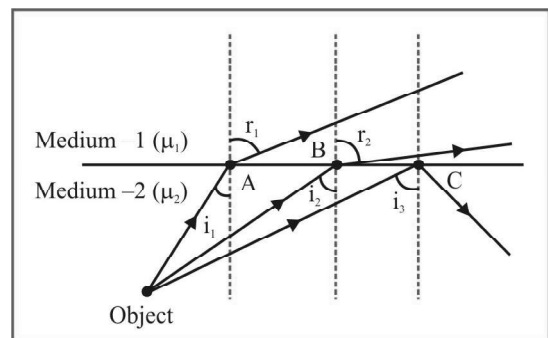

Different rays from the object are shown. As we move from A towards C, angle of incidence goes on increasing. Therefore, the angle of refraction goes on increasing. At B, angle of refraction approaches 90° . This is called critical condition. After B, angle of

incidence increases, but angle of refraction cannot be greater than 90°. Therefore after point B, refraction of light does not take place, only reflection of light takes place. This is called total internal reflection.

5.6 Refraction through Curved Surfaces

Spherical Refracting Surfaces

A spherical refracting surface is a part of a sphere. For example, the plane face of cylindrical glass rod is curved to form a spherical shape (as shown in the figure).

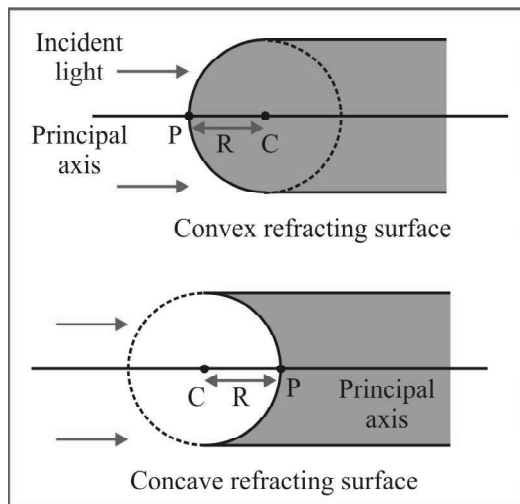

- P → Pole of refracting surface
- C → Centre of curvature
- PC → Radius of curvature

Principal axis : The line joining pole and centre of curvature.

5.7 Relation between Object Distance and Image Distance Refraction at Spherical Surfaces

Consider the point object O placed in the medium with refractive index equal to μ_1 . As $\mu_1 \sin i = \mu_2 \sin r$ and for small aperture $i, r \rightarrow 0$

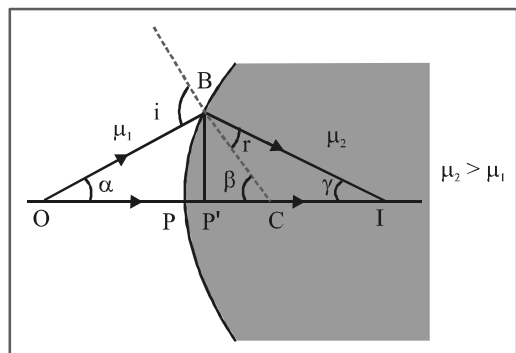

i.e. paraxial rays $\Rightarrow \mu_1 i = \mu_2 r$

$$i = \alpha + \beta, \beta = \begin{cases} \gamma + r, \text{ in fig. I} \\ r - \gamma, \text{ in fig. II} \end{cases}$$

$$\mu_1 (\alpha + \beta) = \mu_2 (\beta \mp \gamma) \text{ in fig. I and fig. II}$$

$$\Rightarrow \mu_1 \alpha \pm \mu_2 \gamma = (\mu_2 - \mu_1) \beta,$$

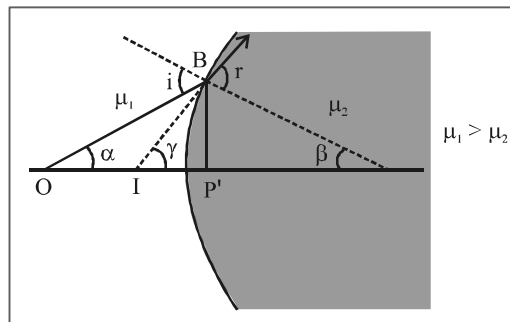

As aperture is small $\alpha \approx \tan \alpha, \beta \approx \tan \beta, \gamma \approx \tan \gamma$

$$\mu_1 \tan \alpha \pm \mu_2 \tan \gamma = (\mu_2 - \mu_1) \tan \beta$$

$$\frac{\mu_1}{P'O} \pm \frac{\mu_2}{P'I} = \frac{\mu_2 - \mu_1}{P'C} \quad \dots(i)$$

Applying sign convention i.e., $u = -P'O$

$v = P'I$ and $-P'I$, in fig. I and fig. II respectively $R = P'C$

Substituting the above values in equation (i), we get

$$\frac{\mu_2}{v} - \frac{\mu_1}{u} = \frac{\mu_2 - \mu_1}{R} \text{ (For both fig. I and fig. II)}$$

5.8 Linear Magnification for Spherical Refracting Surface

$$m = - \frac{(A'B')}{AB}$$

Now, $\frac{\sin i}{\sin r} = \frac{\mu_2}{\mu_1}$

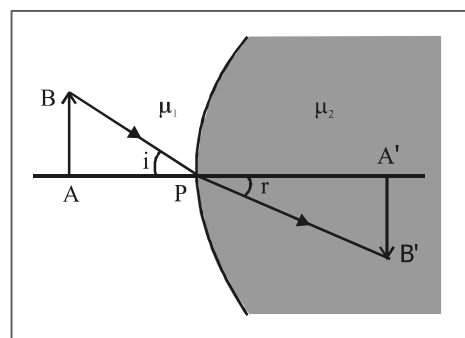

As $i, r \rightarrow 0, i \approx \sin i \approx \tan i, r \approx \sin r \approx \tan r$

$$\frac{\tan i}{\tan r} = \frac{\mu_2}{\mu_1} \text{ or } \frac{AB/PA}{A'B'/PA'} = \frac{\mu_2}{\mu_1}$$

$$\Rightarrow \frac{A'B'}{AB} = \frac{-PA'/\mu_2}{PA/\mu_1}$$

$$\text{Hence, } m = \frac{v/\mu_2}{u/\mu_1}$$

6. THIN LENS

A thin lens is defined as a portion of transparent refracting medium bounded by two surfaces. One of the two surfaces must be curved. Following figures show a number of lenses formed by different refracting surfaces.

A lens is one of the most familiar optical devices for a human being. A lens is an optical system with two refracting surfaces. The simplest lens has two spherical surfaces close enough together that we can neglect the distance between them (the thickness of the lens). We call this a thin lens.

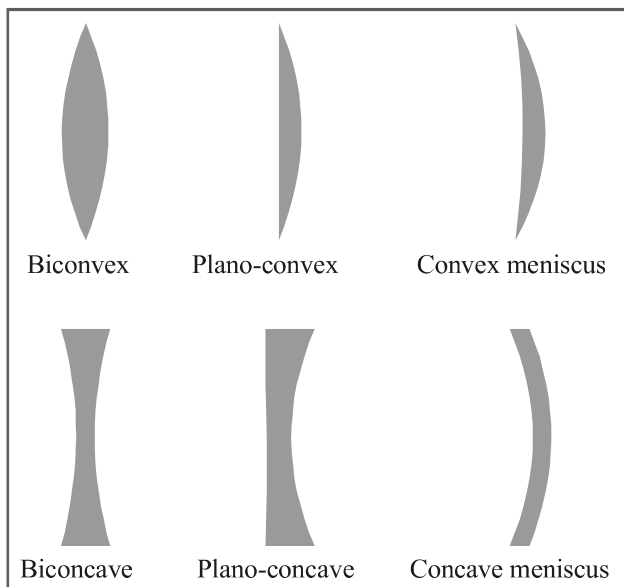

6.1 Terms Related with Lenses

- (i) **Centre of curvature (C_1 and C_2)** : The two bounding surfaces of a lens are each part of a complete sphere. The centre of the sphere is the centre of curvature.
- (ii) **Radius of curvature (R_1 and R_2)** : The radii of the curved surfaces forming the lens are called radii of curvature.
- (iii) **Principal axis** : The line joining the two centres of curvature is called principal axis.
- (iv) **Optical centre** : A point on the principal axis of the lens from which a ray of light passes undeviated.
- (v) **Principal foci** : There are two principal foci of a lens.
- (a) **First principal focus F_1** : It is a point on the principal axis, such that a ray, diverging from the point or converging

towards the point, after refraction becomes parallel to principal axis.

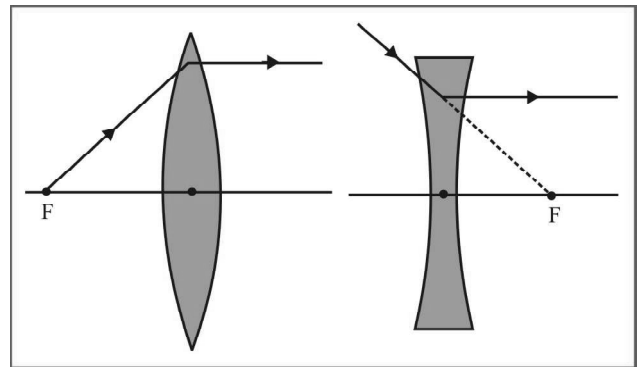

- (b) **Second principal focus F_2** : It is a point on principal axis, such that a ray moving parallel to principal axis, after refraction converges or diverges towards the point.

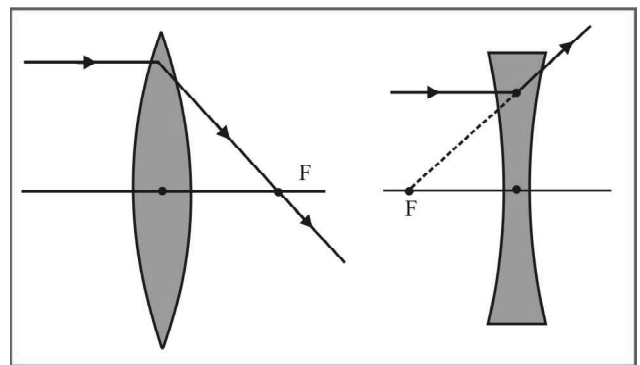

- (vi) **Focal Length** : The distance between optical centre and second principal focus is focal length. Assumptions and sign conventions are same as these of mirrors with optical centre C in place of pole P of the mirror.

6.2 Ray diagram

To construct the image of a small object perpendicular to the axis of a lens, two of the following three rays are drawn from the top of the object.

1. A ray parallel to the principal axis after refraction passes through the principal focus or appears to diverge from it.

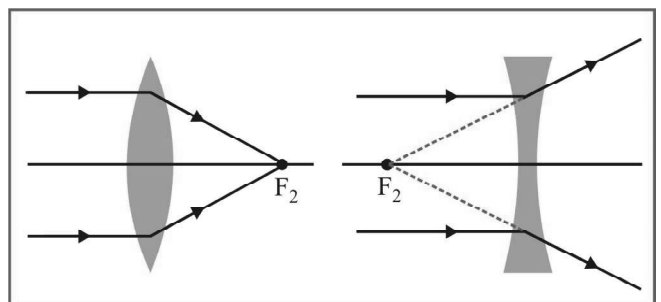

2. A ray through the optical centre P passes undeviated because the middle of the lens acts like a thin parallel-sided slab.

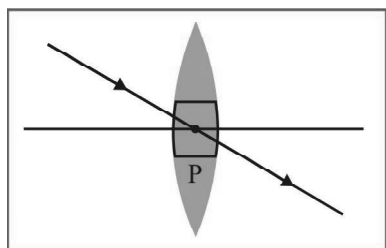

3. A ray passing through the first focus F_1 become parallel to the principal axis after refraction.

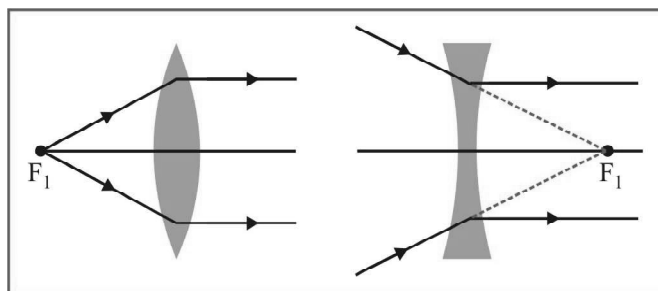

6.3 Image formation by Lens

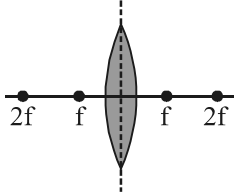
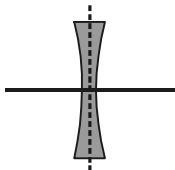
Lens	Location of the object	Location of the image	Nature of image		
			Magnification	<u>Real</u> <u>virtual</u>	<u>Erect</u> <u>inverted</u>
Convex 	At infinity i.e. $u = \infty$	At focus i.e. $v = f$	$m < 1$ diminished	Real	Inverted
	Away from $2f$ i.e. ($u > 2f$)	Between f and $2f$ i.e. $f < v < 2f$	$m < 1$ diminished	Real	Inverted
	At $2f$ or ($u = 2f$)	At $2f$ i.e. ($v = 2f$)	$m = 1$ same size	Real	Inverted
	Between f and $2f$ i.e. $f < u < 2f$	Away from $2f$ i.e. ($v > 2f$)	$m > 1$ magnified	Real	Inverted
	At focus i.e. $u = f$	At infinity i.e. $v = \infty$	$m = \infty$ magnified	Real	Inverted
	Between optical centre and focus, $u < f$	At a distance greater than that of object $v > u$	$m > 1$ magnified	Virtual	Erect
Concave 	At infinity i.e. $u = \infty$	At focus i.e. $v = f$	$m < 1$ diminished	Virtual	Erect
	Anywhere between infinity and optical centre	Between optical centre and focus	$\mu < 1$ diminished	Virtual	Erect



Minimum distance between an object and its real image formed by a convex lens is $4f$.
Maximum image distance for concave lens is its focal length.

6.4 Lens maker's formula and lens formula

Consider an object O placed at a distance u from a convex lens as shown in figure. Let its image I after two refractions from spherical surfaces of radii R_1 (positive) and R_2 (negative) be formed at a distance v from the lens. Let v_1 be the distance of image formed by refraction from the refracting surface of radius R_1 . This image acts as an object for the second surface. Using,

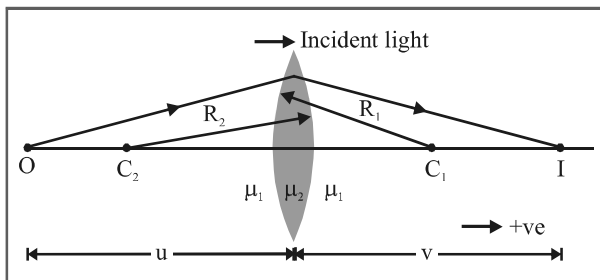

$$\frac{\mu_2}{v} - \frac{\mu_1}{u} = \frac{\mu_2 - \mu_1}{R}$$

twice, we have

or
$$\frac{\mu_2}{v_1} - \frac{\mu_1}{u} = \frac{\mu_2 - \mu_1}{R_1} \quad \dots(i)$$

and
$$\frac{\mu_1}{v} - \frac{\mu_2}{v_1} = \frac{\mu_1 - \mu_2}{R_2} \quad \dots(ii)$$

Adding eqs. (i) and (ii) and then simplifying, we get

$$\frac{1}{v} - \frac{1}{u} = \left(\frac{\mu_2}{\mu_1} - 1\right) \left(\frac{1}{R_1} - \frac{1}{R_2}\right) \quad \dots(iii)$$

This expression relates the image distance v of the image formed by a thin lens to the object distance u and to the thin lens properties (index of refraction and radii of curvature). It is valid only for paraxial rays and only when the lens thickness is much less than R_1 and R_2 . The focal length f of a thin lens is the image distance that corresponds to an object at infinity. So, putting $u = \infty$ and $v = f$ in the above equation, we have

$$\frac{1}{f} = \left(\frac{\mu_2}{\mu_1} - 1\right) \left(\frac{1}{R_1} - \frac{1}{R_2}\right) \quad \dots(iv)$$

If the refractive index of the material of the lens is μ and it is placed in air, $\mu_2 = \mu$ and $\mu_1 = 1$ so that eq. (iv) becomes

$$\frac{1}{f} = (\mu - 1) \left(\frac{1}{R_1} - \frac{1}{R_2}\right) \quad \dots(v)$$

This is called the lens maker's formula because it can be used to

determine the values of R_1 and R_2 that are needed for a given refractive index and a desired focal length f .

Combining eqs. (iii) and (v), we get

$$\frac{1}{v} - \frac{1}{u} = \frac{1}{f} \quad \dots(vi)$$

Which is known as the lens formula. Following conclusions can be drawn from eqs. (iv), (v) and (vi).

1. For a converging lens, R_1 is positive and R_2 is negative.

Therefore, $\left(\frac{1}{R_1} - \frac{1}{R_2}\right)$ in eq. (v) comes out a positive

quantity and if the lens is placed in air, $(\mu - 1)$ is also a positive quantity. Hence, the focal length f of a converging lens comes out to be positive. For a diverging lens however, R_1 is negative and R_2 is positive and the focal length f becomes negative.

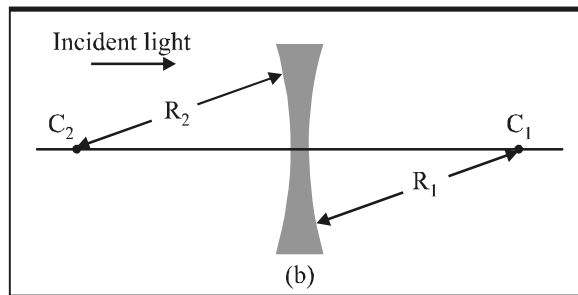
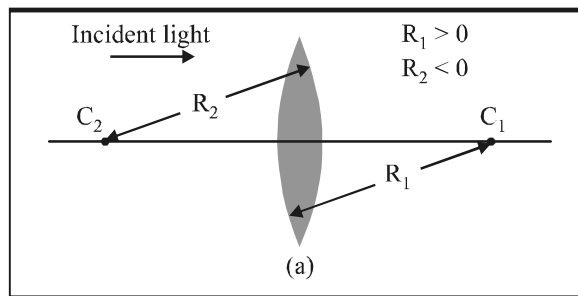

2. Focal length of a mirror ($f_M = R/2$) depends only upon the radius of curvature R while that of a lens [eq. (iv)] depends on μ_1, μ_2, R_1 and R_2 . Thus, if a lens and a mirror are immersed in some liquid, the focal length of lens would change while that of the mirror will remain unchanged.
3. Suppose $\mu_2 < \mu_1$ in eq. (iv), i.e., refractive index of the medium (in which lens is placed) is more than the refractive

index of the material of the lens, then $\left(\frac{\mu_2}{\mu_1} - 1\right)$ becomes a

negative quantity, i.e., the lens changes its behaviour. A converging lens behaves as a diverging lens and vice-versa. An air bubble in water seems as a convex lens but

behaves as a concave (diverging) lens.

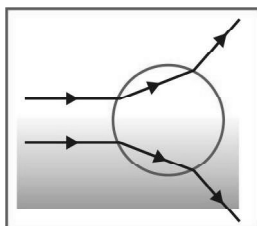

6.5 Magnification

The lateral, transverse of linear magnification m produced by a lens is defined by,

$$m = \frac{\text{height of image}}{\text{height of object}} = \frac{I}{O}$$

A real image II' of an object OO' formed by a convex lens is shown in figure.

$$\frac{\text{height of image}}{\text{height of object}} = \frac{II'}{OO'} = \frac{v}{u}$$

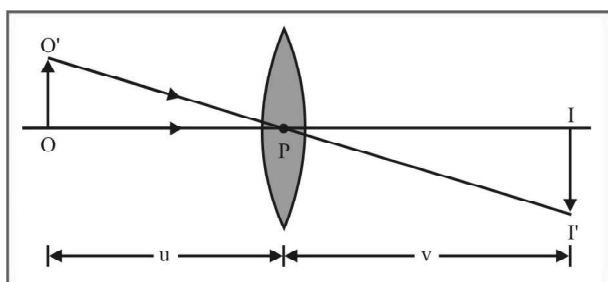

Substituting v and u with proper sign,

$$\frac{II'}{OO'} = \frac{-I}{O} = \frac{v}{-u} \quad \text{or} \quad \frac{I}{O} = m = \frac{v}{u}$$

Thus, $m = \frac{v}{u}$

7. POWER OF AN OPTICAL INSTRUMENT

By optical power of an instrument (whether it is a lens, mirror or a refractive surface) we mean the ability of the instrument to deviate the path of rays passing through it. If the instrument converges the rays parallel to the principal axis its power is said positive and if it diverges the rays it is said a negative power.

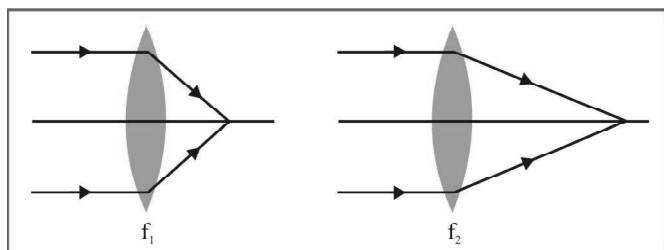

The shorter the focal length of a lens (or a mirror) the more it converges or diverges light. As shown in the figure,

$$f_1 < f_2$$

and hence the power $P_1 > P_2$, as bending of light in case 1 is more than that of case 2. For a lens,

$$P \text{ (in dioptre)} = \frac{1}{f \text{ (metre)}}$$

$$P \text{ (in dioptre)} = \frac{-1}{f \text{ (metre)}}$$

Following table gives the sign of P and f for different type of lens and mirror.

8. COMBINATION OF LENS

(i) For a system of lenses, the net power, net focal length and magnification given as follows :

$$P = P_1 + P_2 + P_3 \dots\dots\dots,$$

$$\frac{1}{F} = \frac{1}{f_1} + \frac{1}{f_2} + \frac{1}{f_3} + \dots\dots\dots,$$

$$m = m_1 \times m_2 \times m_3 \times \dots\dots\dots$$

(ii) When two lenses are placed co-axially at a distance d from each other then equivalent focal length (F).

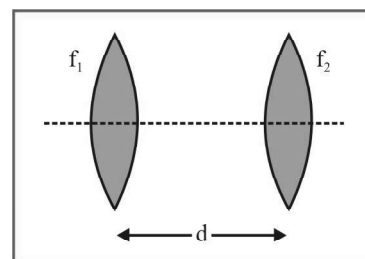

$$\frac{1}{F} = \frac{1}{f_1} + \frac{1}{f_2} - \frac{d}{f_1 f_2} \quad \text{and} \quad P = P_1 + P_2 - dP_1 P_2$$

9. CUTTING OF LENS

(i) A symmetric lens is cut along optical axis in two equal parts. Intensity of image formed by each part will be same as that of complete lens.

(ii) A symmetric lens is cut along principle axis in two equal parts. Intensity of image formed by each part will be less compared as that of complete lens. (aperture of each part is $1/\sqrt{2}$ times that of complete lens)

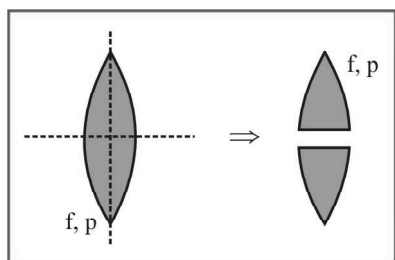
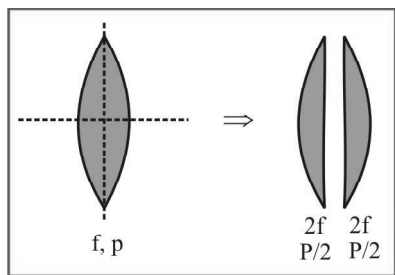

10. SILVERING OF LENS

On silvering the surface of the lens it behaves as a mirror. The

focal length of the silvered lens is $\frac{1}{F} = \frac{2}{f_1} + \frac{1}{f_m}$ where

f_1 = focal length of lens from which refraction takes place (twice)

f_m = focal length of mirror from which reflection takes place.

11. PRISM

A prism has two plane surfaces AB and AC inclined to each other as shown in figure. $\angle A$ is called the angle of prism or refracting angle.

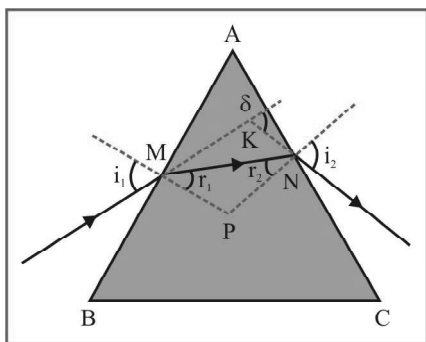

The importance of the prism really depends on the fact that the angle of deviation suffered by light at the first refracting surface, say AB (in 2-dimensional figure) is not cancelled out by the deviation at the second surface AC (as it is in a parallel glass slab), but is added to it. This is why it can be used in a spectrometer, an instrument for analysing light into its component colours.

General Formulae

In quadrilateral AMPN, $\angle AMP + \angle ANP = 180^\circ$

$$\therefore A + \angle MPN = 180^\circ \quad \dots(i)$$

$$\text{In triangle MNP, } r_1 + r_2 + \angle MPN = 180^\circ \quad \dots(ii)$$

From eqs. (i) and (ii), we have

$$r_1 + r_2 = A \quad \dots(iii)$$

11.1 Deviation

Deviation δ means angle between incident ray and emergent ray.

In reflection, $\delta = 180 - 2i = 180 - 2r$

in refraction, $\delta = |i - r|$

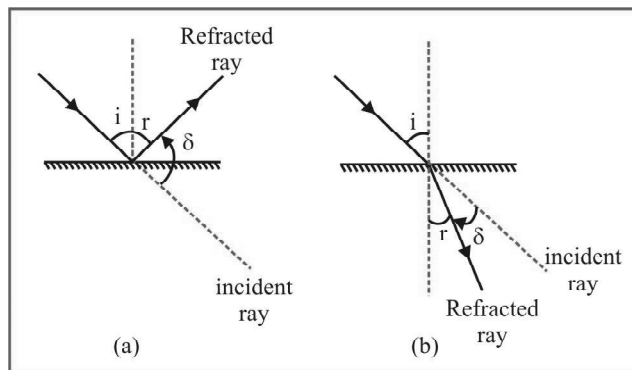

In prism a ray of light gets refracted twice one at M and other at N. At M its deviation is $i_1 - r_1$ and at N it is $i_2 - r_2$. These two deviations are added. So the net deviation is,

$$\delta = (i_1 - r_1) + (i_2 - r_2) = (i_1 + i_2) - (r_1 + r_2) = (i_1 + i_2) - A$$

$$\text{Thus, } \delta = (i_1 + i_2) - A \quad \dots(iv)$$

(i) **If A and i_1 are small :** $\mu = \frac{\sin i_1}{\sin r_1}$, therefore, r_1 will also be

small. Hence, since sine of a small angle is nearly equal to the angle in radians, we have, $i_1 = \mu r_1$

Also, $A = r_1 + r_2$ and so if A and r_1 are small r_2 and i_2 will

also be small. From $\mu = \frac{\sin i_2}{\sin r_2}$, we can say, $i_2 = \mu r_2$

Substituting these values in eq. (iv), we have

$$\delta = (\mu r_1 + \mu r_2) - A = \mu (r_1 + r_2) - A = \mu A - A$$

$$\text{or } \delta = (\mu - 1)A \quad \dots(v)$$

(ii) **Minimum deviation :** It is found that the angle of deviation δ varies with the angle of incidence i_1 of the ray incident on the first refracting face of the prism. The variation is shown in figure and for one angle of incidence it has a minimum value δ_{\min} . At this value the ray passes symmetrically through the prism (a fact that can be proved theoretically as well as be shown experimentally), i.e., the angle of emergence of the ray from the second face equals the angle of incidence of the ray on the first face.

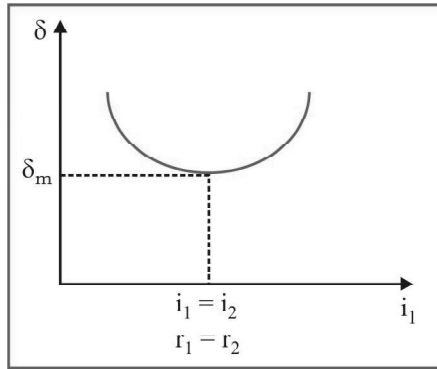

$$i_2 = i_1 = i \quad \dots(vi)$$

It therefore, follows that

$$r_1 = r_2 = r \quad \dots(vii)$$

From eqs. (iii) and (vii)

$$r = \frac{A}{2}$$

Further at, $\delta = \delta_m = (i + i) - A$

$$\text{or } i = \frac{A + \delta_m}{2} \quad \dots(viii)$$

$$\therefore \mu = \frac{\sin i}{\sin r}$$

$$\text{or } \mu = \frac{\sin \left(\frac{A + \delta_m}{2} \right)}{\sin \frac{A}{2}} \quad \dots(ix)$$

11.2 Condition of no emergence

In this section we want to find the condition such that a ray of light entering the face AB does not come out of the face AC for any value of angle i_1 , i.e., TIR takes place on AC

$$r_1 + r_2 = A \quad \therefore r_2 = A - r_1$$

$$\text{or } (r_2)_{\min} = A - (r_1)_{\max} \quad \dots(x)$$

Now, r_1 will be maximum when i_1 is maximum and maximum value of i_1 can be 90° .

$$\text{Hence, } \mu = \frac{\sin (i_1)_{\max}}{\sin (r_1)_{\max}} = \frac{\sin 90^\circ}{\sin (r_1)_{\max}}$$

$$\therefore \sin (r_1)_{\max} = \frac{1}{\mu} = \sin \theta \quad \therefore (r_1)_{\max} = \theta$$

$$\therefore \text{From eq. (x), } (r_2)_{\min} = A - \theta_c \quad \dots(xi)$$

Now, if minimum value of r_2 is greater than θ_c then obviously all values of r_2 will be greater than θ_c and TIR will take place under all conditions. Thus, the condition of no emergence is, $(r_2)_{\min} > \theta_c$ or $A - \theta_c > \theta$

$$\text{or } A > \frac{\theta}{2} \quad \dots(xii)$$

11.3 Dispersion and deviation of light by a prism

White light is a superposition of waves with wavelengths extending throughout the visible spectrum. The speed of light in vacuum is the same for all wavelengths, but the speed in a material substance is different for different wavelengths. Therefore, the index of refraction of a material depends on wavelength. In most materials the value of refractive index μ decreases with increasing wavelength.

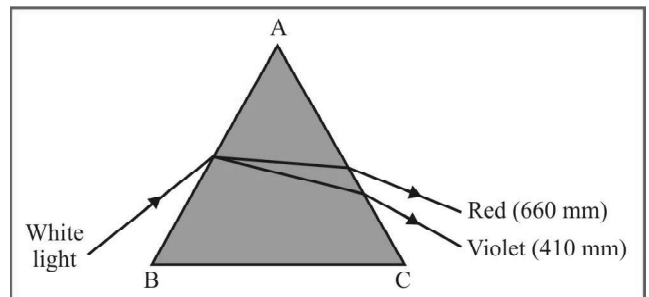

If a beam of white light, which contains all colours, is sent through the prism, it is separated into a spectrum of colours. The spreading of light into its colour components is called dispersion.

11.4 Dispersive Power

When a beam of white light is passed through a prism of transparent material light of different wavelengths are deviated by different amounts. If δ_r , δ_y and δ_v are the deviations for red, yellow and violet components then average deviation is measured by δ_y as yellow light falls in between red and violet. $\delta_v - \delta_r$ is called angular dispersion. The dispersive power of a material is defined as the ratio of angular dispersion to the average deviation when a white beam of light is passed through it. It is denoted by ω . As we know

$$\delta = (\mu - 1) A$$

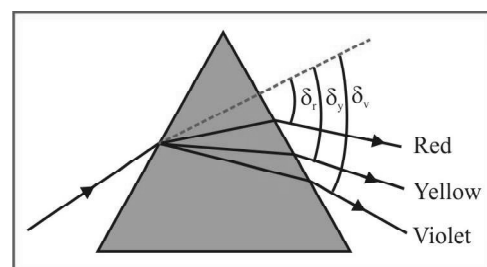

RAY OPTICS

This equation is valid when A and i are small. Suppose, a beam of white light is passed through such a prism, the deviation of red, yellow and violet light are

$$\delta_r = (\mu_r - 1)A, \delta_y = (\mu_y - 1)A \text{ and } \delta_v = (\mu_v - 1)A$$

The angular dispersion is $\delta_v - \delta_r = (\mu_v - \mu_r)A$ and the average deviation is $\delta_y = (\mu_y - 1)A$. Thus, the dispersive power of the medium is,

$$\omega = \frac{\mu_v - \mu_r}{\mu_y - 1} \dots(i)$$

12. MONOCHROMATIC ABERRATIONS IN MIRRORS AND LENSES

(INDEPENDENT OF WAVELENGTH)

Spherical aberration : because of the fact that all rays are not paraxial. The image of a point object formed by a spherical mirror is a surface, whose 2-D view is called a 'caustic curve'. When a real image is seen on a screen and the screen is moved forward/backward slightly, a disc image is formed which becomes smallest at one position. The periphery of this smallest disc is called 'the circle of least confusion'. Lenses too exhibit spherical aberration. We can reduce it by blocking non-paraxial rays but this reduces the brightness of the image. A ring shaped black paper is affixed on the lens so that only those rays pass through the 'hole' in the ring, which are paraxial. Parabolic mirrors do not exhibit any spherical aberration, hence all expensive reflecting telescopes use parabolic mirrors.

In lenses, spherical aberration can be reduced by using a combination of convex and concave lenses, which cancel out each other's aberrations.

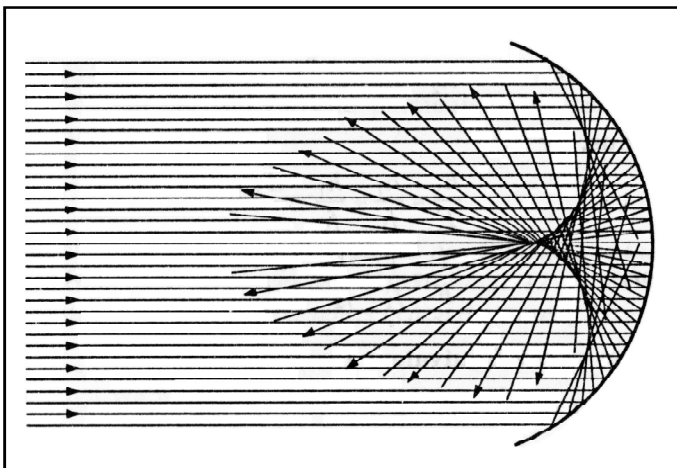

Coma : Consider a point object placed 'off' the optical axis. Most of the rays focus at a single point, but others form images at different points so that the overall image is like that of a 'comet'

(☾) having a sharp 'point' image followed by a trail like that of a comet.

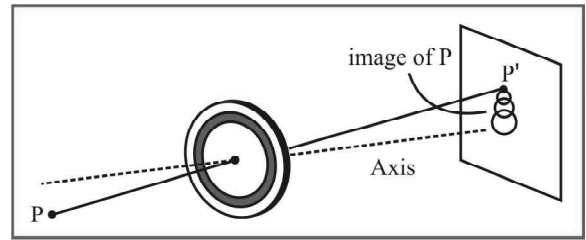

Coma can be reduced by carefully working out the curvature function, or by blocking off the rays that create the 'tail' of the comet shaped image.

- **Astigmatism** : The shape of the image is different at different distances. Suppose a point object is placed off the optical axis of a converging lens. Then, as a lateral screen is moved along the axis, at one point, the image is almost a line. At other positions of the screen, the image changes into an different shapes at different locations of the screen.

Astigmatism can be reduced by using non-spherical surfaces of revolution-such corrected lenses are called 'anastigmatic'.

- **Curvature** : Consider a point object placed off the optical axis of a lens. We have seen that image is spread out laterally as well as longitudinally, with individual defects in each direction. However, the best image is obtained on a curved surface and not on a plane screen. This phenomenon is called 'curvature'.

- **Distortion** : A square lateral object has images, which are either 'barrel shaped' or 'curving in' as shown. This is because the lateral magnification itself depends on the actual distance of a portion of the object from the optical axis. These different magnifications of different portions produce this effect.

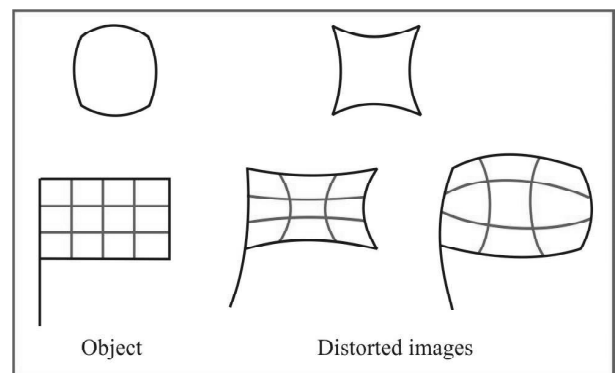

13. CHROMATIC ABERRATIONS IN LENSES (DEPENDENT ON WAVELENGTH)

These aberrations are absent in mirrors. In lenses, the focal length depends on the refractive index, which is different for different colors. Hence, colored images are formed at different points if white light is emitted by the object. A proper combination of convex and concave lenses exactly cancel out each others chromatic

aberration (for light having two wavelengths only) so that the final image is not split into colored images. Such a combination is called an ‘achromatic doublet’. The distance along the optical axis between images of violet and red is called ‘axial or longitudinal chromatic aberration’ = LCA (say):

For an incident parallel beam of white light, image distance = focal length. From lens-makers formulae:

$-df/f = dn/(n-1) = \omega = \text{dispersive power of lens} \approx (n_v - n_r)/(n-1)$
 $\Rightarrow \text{LCA} = \Delta f \approx \omega f$. For two thin lenses in contact, $(1/F) = (1/f_1) + (1/f_2)$. Therefore, $dF = 0 \Rightarrow \omega_1/f_1 = -\omega_2/f_2 \rightarrow \text{achromatic lens}$. An achromatic ‘doublet’ or lens combination can be made by placing two thin lenses in contact, with one converging and the other diverging, made of different materials.

For lateral objects, images of different colors have different sizes as magnification itself depends on the focal length, which is different for different colors. The difference in the size of lateral images of violet and red colors is called ‘lateral chromatic aberration’.

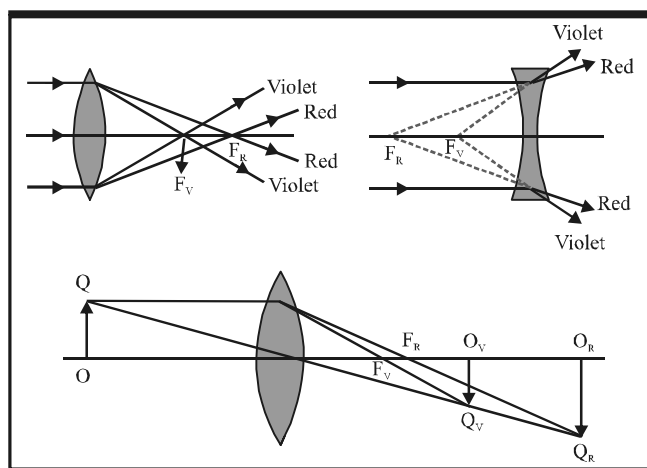

14. OPTICAL INSTRUMENTS

14.1 Simple Microscope or Magnifying Glass

A simple microscope is used for observing magnified images of tiny objects. It consists of a converging lens of small focal length. A virtual, erect and magnified image of the object is formed at the least distance of distinct vision from the eye held close to the lens. That is why the simple microscope is also called a magnifying glass.

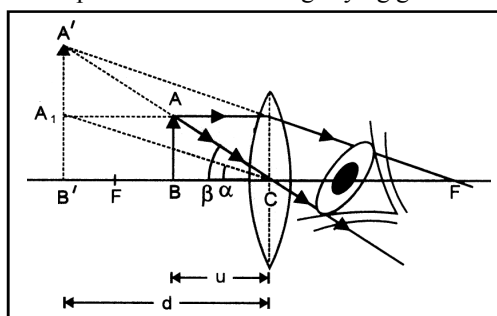

Magnifying power of a simple microscope is defined as the ratio of the angles subtended by the image and the object on the eye, when both are at the least distance of distinct vision from the eye.

By definition, Magnifying power $m = \frac{\beta}{\alpha}$... (1)

For small angles expressed in radians, $\tan \theta \approx \theta$

$\therefore \alpha \approx \tan \alpha$ and $\beta \approx \tan \beta$

$\therefore m = \frac{\tan \beta}{\tan \alpha}$... (2)

In ΔABC , $\tan \beta = \frac{AB}{CB}$

In $\Delta A_1B'C$, $\tan \alpha = \frac{A_1B'}{CB'} = \frac{AB}{CB'}$

Putting in (2), we get

$m = \frac{AB}{CB} \times \frac{CB'}{AB} = \frac{CB'}{CB} = \frac{-v}{-u} = \frac{v}{u}$... (3)

where, $CB' = -v$, distance of image from the lens, $CB = -u$, distance of object from the lens

From lens formula, $\frac{1}{v} - \frac{1}{u} = \frac{1}{f}$

Multiply both sides by v

$1 - \frac{v}{u} = \frac{v}{f}$

using (3), $1 - m = \frac{v}{f}$

or $m = 1 - \frac{v}{f}$

But $v = -d$, $\therefore m = \left(1 + \frac{d}{f}\right)$

14.2 Compound Microscope

A compound microscope is an optical instrument used for observing highly magnified images of tiny objects.

Construction : A compound microscope consists of two converging lenses (or lens system); an objective lens O of very small focal length and short aperture and an eye piece E of moderate focal length and large aperture.

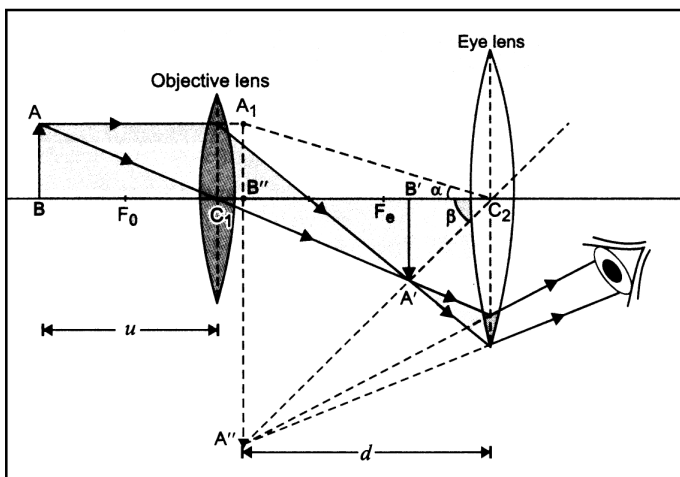

Magnifying power of a compound microscope is defined as the ratio of the angle subtended at the eye by the final image to the angle subtended at the eye by the object, when both the final image and the object are situated at the least distance of distinct vision from the eye.

In figure, $C_2B'' = d$. Imagine the object AB to be shifted to $_1B''$ so that it is at a distance d from the eye. If $\angle A''C_2B'' = \beta$ and $\angle A_1C_2B'' = \alpha$, then by definition,

$$\text{Magnifying power, } m = \frac{\beta}{\alpha} \quad \dots(1)$$

For small angles expressed in radians, $\tan \theta \approx \theta$

$$\therefore \alpha \approx \tan \alpha \text{ and } \beta \approx \tan \beta$$

$$\text{From (1), } m = \frac{\tan \beta}{\tan \alpha} \quad \dots(2)$$

$$\text{In } \Delta A''B''C_2, \quad \tan \beta = \frac{A''B''}{C_2B''}$$

$$\text{In } \Delta A_1B''C_2, \quad \tan \alpha = \frac{{}_1B''}{C_2B''} = \frac{AB}{C_2B''}$$

Putting in (2), we get

$$m = \frac{{}_1B''}{C_2B''} \times \frac{C_2B''}{AB} = \frac{{}_1B''}{AB} = \frac{{}_1B''}{A'B'} \times \frac{A'B'}{AB}$$

$$m = m_e \times m_o$$

where $m_e = \frac{{}_1B''}{A'B'}$, magnification produced by eye lens,

and $m_o = \frac{A'B'}{AB}$, magnification produced by objective lens.

$$\text{Now, } m_e = \left(1 + \frac{d}{f_e}\right)$$

where d is $C_2B'' =$ least distance of distinct vision, f_e is focal length of eye lens. And

$$m_o = \frac{A'B'}{AB} = \frac{\text{distance of image } A'B' \text{ from } C_1}{\text{distance of object } AB \text{ from } C_1}$$

$$= \frac{C_1B'}{C_1B} = \frac{v_o}{-u_o}$$

Putting these values in (3), we get

$$m = \frac{v_o}{-u_o} \left(1 + \frac{d}{f_e}\right) = \frac{v_o}{|u_o|} \left(1 + \frac{d}{f_e}\right) \quad \dots(4)$$

As the object AB lies very close to F_o , the focus of objective lens, therefore,

$$u_o = C_1B \approx C_1F_o = f_o = \text{focal length of objective lens.}$$

As $A'B'$ is formed very close to eye lens whose focal length is also short, therefore,

$$v_o = C_1B' \approx C_1C_2 = L = \text{length of microscope tube.}$$

Putting in (4), we get

$$m = \frac{L}{-f_o} \left(1 + \frac{d}{f_e}\right) = \frac{L}{|f_o|} \left(1 + \frac{d}{f_e}\right) \quad \dots(5)$$

14.3 Astronomical Telescope

An astronomical telescope is an optical instrument which is used for observing distinct image of heavenly bodies like stars, planets etc.

It consists of two lenses (or lens systems), the objective lens, which is of large focal length and large aperture and the eye lens, which has a small focal length and small aperture. The two lenses are mounted co-axially at the free ends of the two tubes.

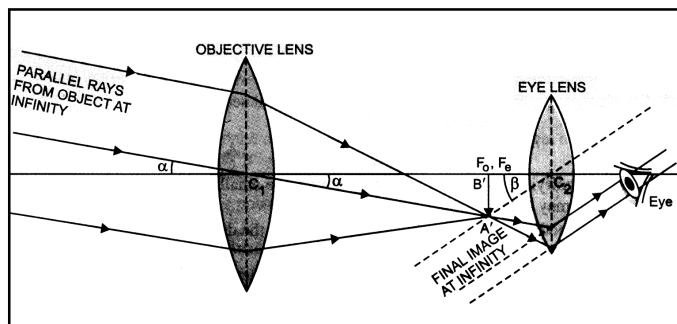

However, in astronomical telescope, final image being inverted with respect to the object does not matter, as the astronomical objects are usually spherical.

Magnifying Power of an astronomical telescope in normal adjustment is defined as the ratio of the angle subtended at

the eye by the final image to the angle subtended at the eye, by the object directly, when the final image and the object both lie at infinite distance from the eye.

$$\text{Magnifying power, } m = \frac{\beta}{\alpha} \quad \dots(1)$$

As angles α and β are small, therefore, $\alpha \approx \tan \alpha$ and $\beta \approx \tan \beta$.

$$\text{From (1), } m = \frac{\tan \beta}{\tan \alpha} \quad \dots(2)$$

$$\text{In } \Delta A'B'C_2, \tan \beta = \frac{A'B'}{C_2B'}$$

$$\text{In } \Delta A'B'C_1, \tan \alpha = \frac{A'B'}{C_1B'}$$

$$\text{Put in (2), } m = \frac{A'B'}{C_2B'} \times \frac{C_1B'}{A'B'} = \frac{C_1B'}{C_2B'}$$

$$\text{or } m = \frac{f_0}{-f_e} \quad \dots(3)$$

where $C_1B' = f_0 =$ focal length of objective lens.

$C_2B' = -f_e =$ focal length of eye lens.

Negative sign of m indicates that final image is inverted.

Memory Note

- (i) In normal adjustment of telescope, distance between the objective lens and eye lens = $(f_0 + f_e)$.
- (ii) Angular magnification produced by the telescope = β/α . Clearly, visual angle β is much larger as compared to α .

Figure shows the course of rays in an astronomical telescope, when the final image is formed at the least distance of distinct vision (d) from the eye)

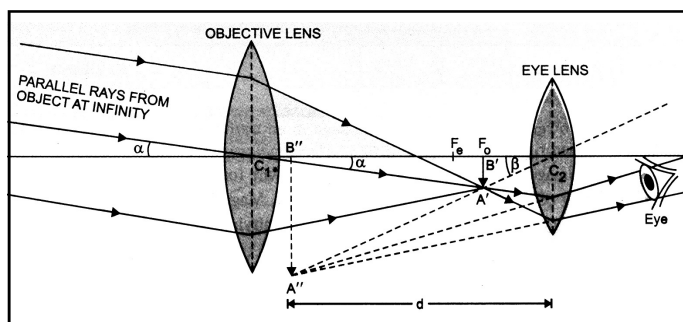

Magnifying power of an astronomical telescope is defined as the ratio of the angle subtended at the eye by the final image at the least distance of distinct vision to the angle subtended at the eye by the object at infinity, when seen directly.

$$\therefore \angle A'C_1B' = \alpha$$

Further, let $\angle A''C_2B'' = \beta$, where $C_2B'' = d$

$$\therefore \text{By definition, Magnifying power, } m = \frac{\beta}{\alpha} \quad \dots(4)$$

As angles α and β are small, therefore, $\beta \approx \tan \beta$ and $\alpha \approx \tan \alpha$

$$\text{From (4), } m = \frac{\tan \beta}{\tan \alpha} \quad \dots(5)$$

$$\text{In } \Delta A'B'C_2, \tan \beta = \frac{A'B'}{C_2B'}$$

$$\text{In } \Delta A'B'C_1, \tan \alpha = \frac{A'B'}{C_1B'}$$

$$\text{Putting in (5), we get } m = \frac{A'B'}{C_2B'} \times \frac{C_1B'}{A'B'}$$

$$m = \frac{C_1B'}{C_2B'} = \frac{f_0}{-u_e} \quad \dots(6)$$

where $C_1B' = f_0 =$ focal length of objective lens

$C_2B' = -u_e,$ distance of $A'B'$, acting as the object for eye lens.

$$\text{Now, for eye lens, } \frac{1}{v} - \frac{1}{u} = \frac{1}{f}$$

Taking $v_e = -d, u = -u_e$ and $f = +f_e$, we get

$$\frac{1}{-d} - \frac{1}{-u_e} = \frac{1}{f_e}$$

$$\frac{1}{u_e} = \frac{1}{f_e} + \frac{1}{d} = \frac{1}{f_e} \left(1 + \frac{f_e}{d} \right)$$

$$\text{Putting in (6), we get } m = -\frac{f_0}{f_e} \left(1 + \frac{f_e}{d} \right)$$

Discussion :

- (i) As magnifying power is negative, the final image in an astronomical telescope is inverted i.e. upside down and left turned right.
- (ii) As intermediate image is between the two lenses, cross wire (or measuring device) can be used.
- (iii) In normal setting of telescope, final image is at infinity. Magnifying power is minimum.

When final image is at least distance of distinct vision, magnifying power is maximum. Thus

$$(M.P.)_{\min.} = -\left[\frac{f_0}{f_e} \right]; (M.P.)_{\max.} = -\frac{f_0}{f_e} \left(1 + \frac{f_e}{d} \right)$$